

Housed Drum Magnet

At A Glance



Protection: Primary



Feed Type: Conveyor



Material Type: NdFeb



Cleaning Type: Automatic

Our high intensity housed drum magnet is ideal for the continuous removal of tramp ferrous contamination from any dry bulk material. It is regularly installed in the most arduous of environments.

Housed drums should be fitted at the discharge end of conveyors, vibratory feeders or in-line chute sections.

High performance Rare Earth magnets are contained within a stainless steel wear-resistant drum shell. Cleaning is continuous: the drum rotates taking contamination away from the static magnets.



Benefits

- Reduces spark risk
- Allows difficult products to be screened
- Continuous self cleaning
- High volume capacity
- Removes large to medium sized contamination

Performance

Magnetic Performance	3,500 Gauss
Magnetic field depth	215mm Dia. = 85mm, 315mm Dia. = 100mm 400mm Dia. = 150mm*
Electrical Spec	400 Volts industrial three phase IP54 rated motor gearbox
Temperature	-5°C / +40°C

Suitability

Suitable Products	Dry powders, granulates, grain and sand etc.
Suitable Location	End of conveyor belt, vibratory feeder or in-line chute sections

*Mild steel test piece Ø 5mm x 25mm long

Materials

Magnetic Material	Rare Earth Neodymium Iron Boron - (NdFeb)
Drum Shell	304 grade stainless steel
Sealing	Self adhered white foam (FDA)
Surface Finish	Brushed

Cleaning

As the drum rotates, carry-over fins move the contamination to the rear of the drum, where the magnetic area ends, and out of the magnetic field. It then falls through the reject chute section of the housing. The drum rotates at between 20–25 RPM ensuring that even the most heavily contaminated product can be separated.

Options

- 316 grade stainless steel
- ATEX certified
- Higher temperature versions available

Housed Drum Magnet

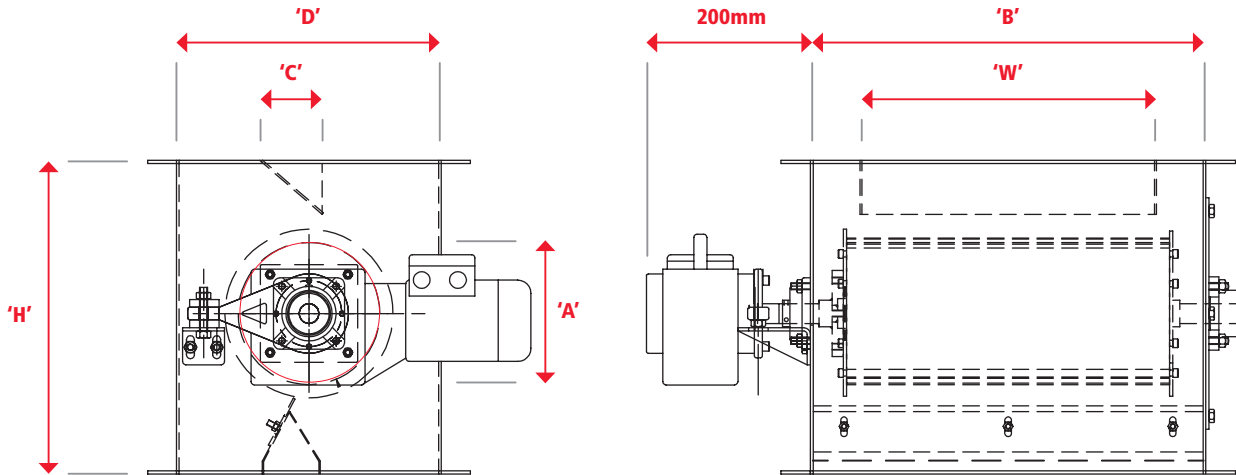

Part Number	Diameter A (mm)	B (mm)	Dia. C (mm)	D (mm)	W (mm)	H (mm)	Weight (kg)
HDMN2140	215	500	75	400	350	475	125
HDMN2150	215	600	75	400	450	475	135
HDMN2160	215	700	75	400	550	475	150
HDMN2170	215	800	75	400	650	475	165
HDMN2180	215	900	75	400	750	475	185
HDMN2190	215	1000	75	400	850	475	210
HDMN21100	215	1100	75	400	950	475	235
HDMN3140	315	500	125	500	350	650	150
HDMN3150	315	600	125	500	450	650	160
HDMN3160	315	700	125	500	550	650	175
HDMN3170	315	800	125	500	650	650	200
HDMN3180	315	900	125	500	750	650	220
HDMN3190	315	1000	125	500	850	650	245
HDMN31100	315	1100	125	500	950	650	275
HDMN4040	400	500	175	585	350	750	185
HDMN4050	400	600	175	585	450	750	205
HDMN4060	400	700	175	585	550	750	220
HDMN4070	400	800	175	585	650	750	240
HDMN4080	400	900	175	585	750	750	265
HDMN4090	400	1000	175	585	850	750	290
HDMN40100	400	1100	175	585	950	750	315

For non-standard sizes, please contact sales@eclipsemagnetics.com